

# LEUKOCYTE ADHESION DEFICIENCY: An Inherited Defect in the Mac-1, LFA-1, and p150,95 Glycoproteins

*Donald C. Anderson, M.D.*

Departments of Pediatrics and Cell Biology, Baylor College of Medicine,  
Texas Children's Hospital, Houston, Texas 77030

*Timothy A. Springer, Ph.D.*

Department of Pathology, Harvard Medical School and Laboratory of  
Membrane Immunochemistry, Dana-Farber Cancer Institute, Boston,  
Massachusetts 02115

## ABSTRACT

Leukocyte adhesion deficiency (LAD) is a recently recognized autosomal-recessive trait characterized by recurrent bacterial infections, impaired pus formation and wound healing, and abnormalities in a wide spectrum of adherence-dependent functions of granulocytes, monocytes, and lymphoid cells. Features of this disease are attributable to deficiency (or absence) of cell surface expression of a family of functionally and structurally related glycoproteins. These include Mac-1 (complement receptor type 3), lymphocyte function-associated antigen-1 (LFA-1), and p150,95. Defective biosynthesis of the  $\beta$  chain shared by each molecule (comprised of  $\alpha_1\beta_1$  complexes) represents the fundamental molecular basis of this disease. Recognition of the molecular pathogenesis of this disorder has allowed rich insights into the role of cellular adherence reactions in inflammation and host defense.

## *Introduction*

A family of three glycoproteins with identical  $\beta$  subunits of  $M_r = 95,000$  has recently been defined on leukocyte cell surfaces (1). Each glycoprotein

has a different  $\alpha$  subunit of  $M_r = 150,000$  to  $180,000$  associated with the  $\beta$  subunit in an  $\alpha\beta$  complex. These glycoproteins function in cell adhesion, as shown by the ability of specific monoclonal antibodies (MABs) to inhibit a wide variety of granulocyte, monocyte, and lymphocyte cell-substrate and cell-cell interactions. Soon after this family of leukocyte adhesion glycoproteins had been defined with MAB, its inherited deficiency was found in a number of patients with recurring bacterial infections and persistent granulocytosis (2-41) (Table 1). This finding served to group these patients under a single clinical entity and at the same time provided a molecular basis for their clinical symptoms. Furthermore, studies on the leukocytes from these patients had already demonstrated a number of striking deficiencies in adhesion and adhesion-dependent functions that appear to underlie a failure to accumulate at inflammatory sites. Together with studies of MABs on normal cells, studies on the patient model have yielded rich insights into the regulation and molecular basis of leukocyte adhesion.

**Table 1** Leukocyte adhesion deficiency patients

	Status		Sex		Last reported age (yrs)	
	Confirmed	Presumed	M	F	Alive	Dead
Anderson et al 1984 (2-11)	11		6	5	6, 5, 11, 16, 38, 9, 12, 13, 9	1, 1
Crowley et al 1980 (12-14)	1		1		9	
Arnaout et al 1982 (13, 15-18)	1		1		10	
Bowen et al 1982 (19-21)	2		1	1	9, 9	
Fischer et al 1983 (22-25)	7	7	5	9	6, <sup>a</sup> 4, <sup>a</sup> 2, <sup>a</sup> 2, <sup>a</sup> 4, 1	0, 0, 0, 0, 0, 1, 1, 1
Thompson et al 1984 (26-28)	4	1	2	2	11	6, 22
Weening et al 1976 (29, 30)	1	2	2	1	22	19, 32
Buescher et al 1985 (31)	1		1		3	
Fujita et al 1986 (32, 33)	2		1	1	2, 1	
Weisman et al 1985 (34)	1		1		2	
Boxer et al 1974 (35, 36)	1	1	2			1, <sup>a</sup> 1 <sup>a</sup>
Hayward et al 1979 (37)		5	3	2	0 <sup>b</sup>	0, 0, 0, 0
Davies et al 1982 (38)		2	1	1		1, 1
Harvath & Andersen 1979 (39)		1	1			2
Bissenden et al 1981 (40)		3		1		0, 0, 0
Neithammer et al 1975 (41)		4	3	1	~1	0, 1, 3
P. Wang and T. A. Springer (unpublished)	1			1	26	
Totals	33	26	33	25	28	29

<sup>a</sup> Bone marrow transplanted.

<sup>b</sup> 0 means the patient was less than 1 year old.

### *Early Reports*

Beginning in 1979, a group of patients were recognized who had widespread bacterial infections, defective neutrophil mobility, and delayed separation of the umbilical cord (5, 22, 37, 38, 40). Other patients with recurring bacterial infections were reported who had defects in initiation of the neutrophil respiratory burst to particulate but not to soluble stimuli (29), defects in neutrophil chemotaxis and phagocytosis (6, 41), or both (39). One of the earliest reported patients with abnormal neutrophil phagocytosis and motility was found to have actin dysfunction (35) but later evaluation suggests adhesion protein deficiency (36).

Crowley et al (12) were the first to propose that the defects in neutrophil chemotaxis and phagocytosis were secondary to an abnormality in adhesion. Their patient's neutrophils adhered weakly and failed to spread on plastic petri dishes; they also lacked a cell surface protein of 110,000  $M_r$ . Subsequently, Arnaout et al (15) and Bowen et al (19) reported patients with recurrent bacterial infections associated with deficiency of neutrophil surface glycoproteins of 150,000  $M_r$  and 180,000  $M_r$ , respectively. Patient neutrophils studied by Bowen et al (19) failed to adhere to a variety of artificial substrates, and electron microscopy showed a failure to flatten and form fine pseudopods. Arnaout et al (15) reported a defect in neutrophil receptor-mediated phagocytosis of opsonized particles but normal neutrophil motility and chemotaxis; because of this latter finding, this patient was at first thought to differ from the others (but see below).

### *The Molecular Deficiency Defined*

The  $M_r$  range of 110,000 to 180,000 of the missing surface glycoprotein was consistent with it being the 165,000- $M_r$   $\alpha$  subunit of Mac-1. Mac-1 had been described in mouse and humans as an  $\alpha\beta$  complex with subunits of  $M_r$  165,000 ( $\alpha$ ) and 95,000 ( $\beta$ ) present on macrophage/monocytes, neutrophils, and large granular lymphocytes (42). Following initial studies by Springer and Arnaout with the Mac-1 MA b (cited in 43), in 1984 Dana et al (16), Anderson et al (2), Beatty et al (20), and Springer et al (3) reported that both the  $\alpha$  and  $\beta$  subunits of Mac-1 (also designated Mo1) were deficient on patient neutrophils. Anderson et al (2), Springer et al (3), and Arnaout et al (13) found that the LFA-1  $\alpha\beta$  complex, which has a  $\beta$  subunit identical to that of Mac-1, is also deficient on patient neutrophils and lymphocytes. Springer et al (3, 9) also found that a third type of  $\alpha\beta$  complex, designated p150,95, was deficient on patient cells. Based on biosynthesis studies and on deficiency of all three  $\alpha$  subunits and the common  $\beta$  subunit, Springer et al proposed that the primary defect was

in the  $\beta$  subunit, and that the  $\beta$  subunit was necessary for cell surface expression of the  $\alpha$  subunits (3). Subsequent to these findings, 30 patients with recurring bacterial infections (including some described above in the section on early reports) were found to lack the Mac-1 and LFA-1 glycoproteins (4, 23, 26–28, 30–32, 44) (Table 1).

Thus a group of patients having the same clinical syndrome and the same molecular defect were defined at the same time. We have previously referred to this syndrome as Mac-1, LFA-1-deficiency disease (3, 4, 45); and others have referred to it as Mo1 deficiency (13). In the interests of brevity and comprehensiveness, we now suggest the name “leukocyte adhesion deficiency” (LAD).

### *The Mac-1, LFA-1, p150,95 Glycoprotein Family*

Before further discussing the interesting clinical and functional defects in leukocyte adhesion deficiency, we discuss (a) the structure and function of the Mac-1, LFA-1 glycoproteins, (b) the molecular basis and inheritance of the genetic defect, and (c) evidence for heterogeneity in the mutations affecting the common  $\beta$  subunit, which are of importance for understanding heterogeneity among patients.

The structure, cell distribution, and function of Mac-1 and the two related glycoproteins that have identical 95,000- $M_r$   $\beta$  subunits are summarized in Table 2. Mac-1 and LFA-1 were defined first in the mouse and then in humans. The molecules in both species are homologous and have such similar properties that they are discussed interchangeably (11, 42, 46, 47). The distribution of Mac-1, LFA-1, and p150,95 is limited to white blood cells (42, 48; A. Bhan and T. A. Springer, unpublished) and hematopoietic precursor cells (49, 50). This is consistent with the fact that bone marrow transplantation can completely cure patients with leukocyte adhesion deficiency (22).

The Mac-1, LFA-1, and p150,95 molecules are  $\alpha\beta$  complexes defined with MAbs specific for their  $\alpha_M$ ,  $\alpha_L$ , and  $\alpha_X$  subunits, respectively (1, 9, 51). Numerous MAbs have been obtained that are specific for each  $\alpha$  subunit, as demonstrated by reactivity with the isolated subunits. Depending on the MAb being used, Mac-1 may also be designated Mo1, OKM1, 60.1, or CD11 (51). The designations LFA-1 and p150,95 are widely accepted. No  $\alpha$ -subunit cross-reactive MAb or serum has thus far been identified. In contrast, MAbs specific for the  $\beta$  subunit do cross-react with all three  $\alpha\beta$  complexes (1).

The distinction among the three  $\alpha$  subunits and the identity of the  $\beta$  subunits are supported by peptide mapping, amino acid sequencing, and physicochemical characteristics (1, 52–54). The amino acid sequences of the  $\alpha_M$ ,  $\alpha_L$ , and  $\alpha_X$  subunits show 33 to 50% identity (54; L. J. Miller

and T. A. Springer, unpublished). Because of this homology, the  $\alpha$  subunits are considered a protein family. It is likely that primordial gene duplication events led to the evolution of the protein family. The  $\alpha\beta$  complexes contain only one  $\alpha$  and one  $\beta$  subunit, as demonstrated by chemical cross-linking (1, 53). The  $\alpha$  and  $\beta$  subunits are noncovalently associated only; no intersubunit disulfide bonds are present. The  $\alpha\beta$  complexes are present on the cell surface (and in intracellular vesicles, see below) and remain associated after solubilization with mild detergents. They can be dissociated by treatment with high pH or SDS.

Mac-1, LFA-1, and p150,95 have different functions in leukocyte adhesion. Mac-1 is a complement receptor (CR3) that binds the ligand

**Table 2** The Mac-1, LFA-1 family

	Mac-1		LFA-1		p150,95	
Subunits ( $M_r \times 10^{-3}$ )	$\alpha M$ (170)	$\beta$ (95)	$\alpha L$ (180)	$\beta$ (95)	$\alpha X$ (150)	$\beta$ (95)
Cell distribution	Monocytes Macrophages Granulocytes Large granular lymphocytes		Lymphocytes Monocytes Granulocytes Large granular lymphocytes		Monocytes Macrophages Granulocytes	
Chemotactic or secretory stimulation increases surface expression	Yes		No		Yes	
Functions inhibited by monoclonal antibodies	Complement Receptor type 3 function (iC3b binding, phagocytosis, and intracellular killing of C3-opsonized microorganisms) Granulocyte, adherence, spreading, aggregation, chemotaxis, and antibody-dependent cellular cytotoxicity		Cytolytic T-lymphocyte-mediated killing and T helper cell responses  Natural killing Antibody-dependent cellular cytotoxicity  Phorbol ester-stimulated lymphocyte aggregation		Granulocyte adherence and aggregation	

Common features: The  $\beta$  subunits appear identical. The  $\alpha$  subunits  $\alpha M$  and  $\alpha L$  are 35% homologous in sequence. The  $\alpha$  and  $\beta$  subunits are noncovalently associated in  $\alpha_1\beta_1$  complexes. Both  $\alpha$  and  $\beta$  subunits are glycosylated and expressed on the cell surface. All functions shown require divalent cations.

iC3b (55). Monoclonal antibodies to Mac-1 inhibit binding and phagocytosis of iC3b-opsionized particles by granulocytes and macrophages (10, 55, 56). Purified Mac-1 and, more recently, p150,95 have been demonstrated to bind iC3b (56, 57). Binding is  $Mg^{+2}$  dependent. The defect in patient cells led to findings that Mac-1 mediates neutrophil adhesion to endothelial cells and a variety of substrates (2, 10, 12). This adhesion, discussed in more detail below, is independent of iC3b binding and may be mediated by a distinct binding site on the Mac-1 molecule.

LFA-1 participates in lymphocyte and monocyte adhesion to cells (58). It can mediate antigen-independent adhesion. LFA-1 also appears to be required for T-lymphocyte antigen-dependent adhesion to and killing of some target cells. Similarly, LFA-1 has been demonstrated to be important in natural killing and antibody-dependent killing by K cells and granulocytes, and in T-lymphocyte helper cell interactions. All LFA-1-dependent functions require  $Mg^{+2}$ . Neutrophil adherence and aggregation (which are Mac-1 dependent, see below) also require  $Mg^{+2}$  (59). Thus  $Mg^{+2}$  dependence is a common theme of functions mediated by the glycoprotein family.

While purified p150,95 has been shown to bind iC3b (57), the functional importance of p150,95 as a cell surface iC3b receptor has yet to be demonstrated (60). p150,95 is important in adherence to surfaces (10), but its functional role is less well defined than that of Mac-1 and LFA-1.

### *Biosynthesis of Mac-1, LFA-1, and p150,95*

Biosynthesis of these glycoproteins has been studied both in the mouse and in humans (1, 61); translation and glycosylation *in vitro* has been studied in the mouse (62). Using cloned probes, researchers have defined the murine Mac-1  $\alpha$ -subunit mRNA of 6 kilobases (63) and the human  $\beta$ -subunit mRNA of 3.2 kilobases (T. K. Kishimoto et al, unpublished). The following model of biosynthesis has emerged (Figure 1). Each of the three  $\alpha$  subunits and the common  $\beta$  subunit is encoded by a separate mRNA. The subunits are synthesized as precursors that are cotranslationally glycosylated with N-linked high mannose carbohydrate groups. After  $\alpha$ - and  $\beta$ -subunit association, which occurs 1–2 hours after synthesis, most of the high mannose groups are converted to complex-type carbohydrates in the Golgi apparatus, and the subunits increase slightly in  $M_r$ . The mature glycoproteins are then transported to the cell surface or to storage sites in intracellular secretory vesicles.

### *Intracellular Stores*

In unstimulated blood granulocytes and monocytes, Mac-1 and p150,95 are present in an intracellular, vesicular compartment as well as on the cell

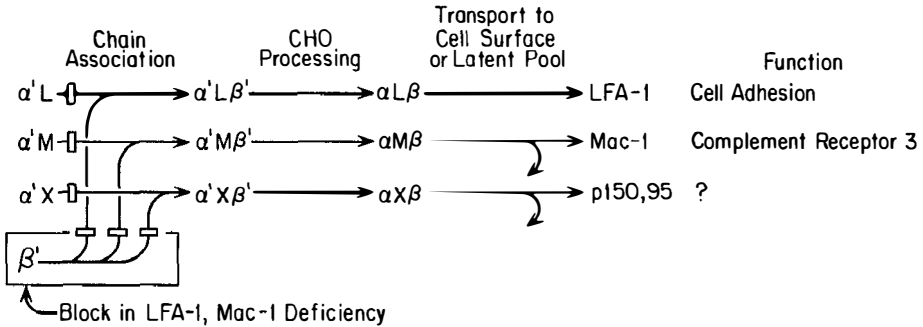

**Figure 1** Biosynthesis of the Mac-1, LFA-1 glycoprotein family. The biosynthetic pathway in normal cells is as described in Reference 1. The evidence for a primary block in  $\beta$ -subunit synthesis, a secondary block in  $\alpha' L$  biosynthesis due to a lack of  $\beta$ -subunit association, and hypothetically similar blocks in  $\alpha' M$  and  $\alpha' X$  biosynthesis, is discussed in the text. Reprinted by permission from *The Journal of Experimental Medicine*.

surface (3, 4, 9, 17, 47). Inflammatory mediators including C5a and f-Met-Leu-Phe stimulate a 5- to 10-fold increase in Mac-1 and p150,95 (but not LFA-1) on the cell surface. This upregulation is apparently of great importance in regulating granulocyte and monocyte adhesiveness. Increased surface expression is nearly maximal within 10 minutes at 37°C and is not impeded by protein synthesis inhibitors. Latent intracellular pools are revealed in unstimulated cells by detergent permeabilization (T. A. Springer and L. J. Miller, unpublished), and Mac-1 is found in neutrophil secondary granules (17). A vesicular storage site in addition to secondary granules may also be present, because mediators such as f-Met-Leu-Phe cause increased Mac-1 expression with little or no secondary granule secretion (T. A. Springer and D. C. Anderson, unpublished). Mac-1 in the intracellular, mobilizable pool is present as an  $\alpha\beta$  complex (17). It is likely that Mac-1 and p150,95 destined for the cell surface and for intracellular storage sites are biosynthesized similarly and differ only in their post-Golgi transport; it is important to distinguish stored Mac-1 from Mac-1 in the process of being biosynthesized.

### *Molecular Deficiency and Severe and Moderate Phenotypes*

Using MAbs specific for the three  $\alpha$  subunits and the common  $\beta$  subunit, researchers found all four subunits to be deficient in patient leukocytes (3, 4, 9). Thus, all three  $\alpha\beta$  complexes are deficient. Patient granulocytes and monocytes are deficient in intracellular stored pools and so is surface expression of the  $\alpha\beta$  complexes, as shown by SDS-PAGE of total cell lysates as well as by the lack of inflammatory mediator-induced up-

regulation of Mac-1 and p150,95 (4, 9, 17). Other leukocyte cell types are also deficient, including peripheral blood lymphocytes and cultured cytolytic T-lymphocytes, mitogen-stimulated T-lymphocytes, and EBV-transformed B-lymphocyte cell lines (3, 8, 13). We have examined ten patients with MAbs specific for all four subunits (4), and other labs have reported studies on MAbs specific for two of the  $\alpha$  subunits and/or the common  $\beta$  subunit (13, 20, 23, 27, 30, 32). There is thus far no example of a selective deficiency in only one or two of the  $\alpha\beta$  complexes; a deficiency in all three appears to be a general finding.

One important difference among patients is in the quantitative extent of deficiency. Among ten patients examined, we have found two phenotypes, which we designate "severe" and "moderate" deficiency (3, 4). As measured by immunofluorescence flow cytometry, and verified by radioimmunoassay and immunoprecipitation, four severely deficient patients have essentially undetectable expression ( $<0.3\%$  of normal amounts) of all three  $\alpha\beta$  complexes on their granulocytes. Six moderately deficient patients express 2.5 to 6% of all three  $\alpha\beta$  complexes. The important correlation between these phenotypes and the severity of clinical symptoms and defects in cell adhesion is discussed below.

### *Inheritance*

Individuals who are clinically unaffected but appear to be heterozygous carriers of LAD have been identified by expression of approximately 50% of normal amounts of the Mac-1  $\alpha$  subunit and the common  $\beta$  subunit on their f-Met-Leu-Phe-stimulated granulocytes (3, 4). In three families we have studied, all the clinically unaffected mothers and fathers and some of the siblings were found to be heterozygous. In one family spanning three generations, an affected son was born to heterozygous parents. The affected son married a heterozygote, and the couple bore an affected son and daughter and two heterozygous daughters. These findings, together with an equal number of male and female patients (Table 1), a frequent history of consanguineous marriages (4, 22, 23, 31, 39, 41), and the presence in many families of both male and female patients (4, 26, 29, 32, 37, 38, 40), strongly suggest that LAD is inherited as a recessive defect on an autosomal chromosome. In one family, X-linked inheritance was found (12, 13). However, no evidence for X-linked chromosome inactivation was reported for the mother, and thus further investigation is required before it can be concluded that LAD is a polygenic defect.

### *The Genetic Lesion*

The molecular basis of the deficiency has thus far been studied via two methods: biosynthesis and human  $\times$  mouse lymphocyte hybrids. Biosyn-



thesis experiments have utilized EBV-transformed B-lymphocyte and mitogen-stimulated T-lymphocyte cell lines, which from healthy individuals synthesize the LFA-1  $\alpha$  subunit and the common  $\beta$  subunit and express the LFA-1  $\alpha\beta$  complex on the cell surface. Early studies showed that patient cell lines synthesized apparently normal LFA-1  $\alpha$ -subunit precursor, but the  $\alpha$ L precursor did not undergo carbohydrate processing, did not associate in an  $\alpha\beta$  complex, and neither subunit was expressed on the cell surface (3) (Figure 1).

In human  $\times$  mouse lymphocyte hybrids, human LFA-1  $\alpha$  and  $\beta$  subunits from normal cells could associate with mouse LFA-1 subunits to form interspecies hybrid  $\alpha\beta$  complexes (11). Surface expression of the  $\alpha$  but not the  $\beta$  subunit of patient cells was rescued by the formation of interspecies complexes. These findings show that the LFA-1  $\alpha$  subunit in genetically deficient cells is competent for surface expression in the presence of an appropriate mouse  $\beta$  subunit; this suggests that the genetic lesion affects the  $\beta$  subunit. Thus the  $\alpha$  subunits must associate with the  $\beta$  subunit in an  $\alpha\beta$  complex in order to mature and be expressed in intracellular pools or on the cell surface (Figure 1). The LFA-1  $\alpha$  subunit is degraded in the absence of the  $\beta$  subunit (3).

Recently, a rabbit anti-human  $\beta$ -subunit serum was developed that allowed  $\beta$ -subunit precursors in both healthy and deficient cell lines to be immunoprecipitated and examined as to size in SDS-PAGE (T. K. Kishimoto, D. C. Anderson, and T. A. Springer, unpublished). These studies show that of four patients, all unrelated, one has an aberrantly large  $\beta$  precursor, two have  $\beta$  precursors of normal size, and one has no  $\beta$  precursor at all. Another group of four patients, all of whom are related to one another and have the moderate phenotype, have a  $\beta$  precursor of identically abnormal small size. Of ten relatives of the family with four patients, nine have been typed as heterozygote carriers and one as a noncarrier by quantity of surface expression (4). All nine heterozygotes show both a normal and an abnormally small  $\beta$  precursor; the noncarrier shows only the normal  $\beta$  precursor. These data provide conclusive evidence that the defect is in the  $\beta$ -subunit gene.

Differences in the  $\beta$ -subunit precursor between unrelated patients suggest distinct mutations in the  $\beta$ -subunit gene. This means that while the moderate and severe phenotypes are useful in a broad sense for categorizing patients, some heterogeneity in the severity or spectrum of clinical symptoms within each category is to be expected. These biosynthesis studies provide no obvious molecular explanation for the moderate and severe phenotypes, because except for one patient the  $\beta$  precursor is synthesized in amounts similar to that in normal cells. We hypothesize that mutant  $\beta$  subunits vary in their ability to complex with the  $\alpha$  subunits, and

this determines the level of expressed  $\alpha\beta$  complex. In mouse  $\times$  human lymphocyte hybrids, the  $\beta$  subunit and hence the genetic lesion has been mapped to chromosome 21 (11). This is in agreement with autosomal inheritance.

### *Clinical and Histopathologic Features*

The clinical and histopathologic features of 30 patients and 20 similar but unconfirmed patients with this disorder (Table 1) have many general characteristics in common. Typical features observed among a cluster of 10 patients in the Houston, Texas, referral area are summarized in Table 3 (4).

Recurrent necrotic and indolent infections of soft tissues primarily involving skin, mucous membranes, and intestinal tract are the clinical hallmarks of LAD. Superficial infections of body surfaces may invade locally or systematically. Typical small, erythematous, nonpustular skin lesions often progress to large, well-demarcated, ulcerative craters, or "pyoderma gangrenosa" (4, 27, 29), which heal slowly or with dysplastic eschars. Staphylococcal or gram-negative enteric bacterial organisms may be cultured from such lesions for up to several weeks despite antimicrobial therapy. Fulminant progression of "gas gangrene" of soft tissues of a distal extremity in one patient prompted surgical amputation as a life-saving measure (19). Septicemia progressing from omphalitis associated with delayed umbilical cord severance has been observed in several infants (4, 22, 37). Perirectal abscess or cellulitis leading to peritonitis and/or septicemia has been reported in multiple patients (4, 15, 19, 37), and facial or deep neck cellulitis has been observed to progress from ulcerative mucous membrane lesions of the oral cavity (4, 19). Recurrent invasive candidal esophagitis and erosive gastritis were prominent clinical features in two patients (29, 38). Three patients in the Texas series have developed acute appendicitis; in one case this was associated with a fatal necrotizing enterocolitis syndrome (4). Nearly fatal peritonitis resulting from a necrotic ileal ulcer occurred in one other patient (40).

Recurrent otitis media occurs commonly, and progression to mastoiditis and facial nerve paralysis has been reported (4, 15, 19, 27, 37). Other common respiratory infections include severe bacterial (pseudomonal) laryngotracheitis (4, 12, 29), recurrent pneumonitis, or sinusitis (4, 19, 27). Severe gingivitis and/or periodontitis is a major feature among all patients who survive infancy. Acute gingivitis has appeared in all cases with eruption of the primary dentition. Subsequently, these patients develop characteristic features of progressive generalized prepubescent periodontitis, including gingival proliferation, defective recessions, mobility, pathologic migration, and advanced alveolar bone loss associated with periodontal

Table 3. Clinical features of Mac-1, LFA-1, p150,95 deficiency syndrome in Texas patients

Clinical features	Severe deficiency				Moderate deficiency					
	#1 18M/0 F <sup>a</sup>	#2 16M/0 F <sup>a</sup>	#3 6 Y/0 F	#9 6 Y/0 M	#4 11Y/0 M	#5 16Y/0 M	#6 38Y/0 M	#7 9Y/0 M	#8 12Y/0 F	#10 13Y/0 M
Delayed umbilical cord severance	+	+	+	-	-	-			-	-
Persistent granulocytosis (15-161,000/mm <sup>3</sup> )	+	+	+	+	+	+	+	+	+	±
Recurrent soft tissue infections										
necrotic cutaneous abscess or cellulitis	+	+	+	+	+	+	+	+	+	+
perirectal cellulitis/sepsis	+	+	+	+	-	-	-	-	-	-
stomatitis/facial cellulitis	+	+	+	+	+	+	+			
gingivitis/periodontitis	+	+	+	+	+	+	+	+	+	+
pneumonitis	+	+	+	+		-	+	+		
necrotizing enterocolitis peritonitis/septicemia	+	-	+	-	-	-	-	-	-	-
Impaired wound healing	+	+	+	-	+	+	++			
Parental consanguinity	-	+		+			±	±	±	-
Ethnic background	Iranian	Hispanic	Anglo-saxon	Hispanic	Hispanic	Hispanic	Hispanic	Hispanic	Hispanic	Canadian

<sup>a</sup> Deceased.

pocket formation and partial or total loss of both the deciduous and permanent dentitions (4, 64).

The recurrent necrotic soft tissue infections observed in affected patients appear to reflect a profound impairment of leukocyte mobilization into extravascular inflammatory sites. Rebeck skin windows as well as biopsies of infected cutaneous, periodontal, umbilical cord, or other soft tissues demonstrate inflammatory infiltrates totally devoid of neutrophilic granulocytes (4, 19, 34). This histopathologic feature is particularly striking considering that marked peripheral blood granulocytosis (5- to 20-fold higher than normal) is a constant and characteristic feature of this disorder. Leukocyte transfusions result in the appearance of granulocytes and monocytes in Rebeck skin windows and in skin chambers (19; D. C. Anderson, unpublished), and often are accompanied by a drop in the peripheral blood white count. Preferential localization of donor as opposed to host leukocytes (>97% of donor origin) in an abscess has been found (19).

Impaired healing of traumatic or surgical wounds observed in several of our patients represents a clinical feature of LAD not found in neutropenia syndromes or other disorders of granulocyte function (4, 19, 27, 35, 64). Unusual paper-thin or dysplastic cutaneous scars characterized three patients of the Texas series as well as two patients described by Ross et al (27). This may reflect the lack of monocyte infiltration and the lack of inflammatory contributions to "healing" such as the elaboration of angiogenesis factors (4).

The wide spectrum of gram-positive or gram-negative bacterial and fungal infectious microorganisms (2, 4, 12, 15, 19, 22, 24, 27, 29-32, 34, 35, 37, 38, 40) is also characteristic of patients with primary neutropenia syndromes or individuals with a genetic deficiency of neutrophil-specific granules. These other clinical models also demonstrate insufficient tissue leukocyte infiltration. However, deep-seated granulomatous infections characteristic of chronic granulomatous disease and other examples of oxidative or nonoxidative intracellular killing deficits have not been observed.

Whether susceptibility to viral infection is increased in this disorder is uncertain. Most patients in the Texas series and several patients reported elsewhere have demonstrated normal and self-limiting courses of varicella or other viral respiratory infections. Five of ten patients in the Texas series demonstrated no untoward reactions to live viral vaccine administration. However, patient #3 of the Texas series died of an overwhelming infection with picornavirus involving oral pharynx, glottis, trachea, and lungs; and three patients of the same series had one or more episodes of aseptic (presumably viral) meningitis (4).

The severity of clinical infectious complications among patients appears

to be directly related to the degree of glycoprotein deficiency (Table 3). In our series, two of four patients with "severe" deficiency died in infancy, and those surviving infancy have demonstrated a susceptibility to severe, life-threatening systemic infections (peritonitis, septicemia, pneumonitis, aseptic meningitis). In contrast, among six patients (five of whom are related) with "moderate" deficiency (mean age 21 years, range 9–38 years), life-threatening infections have been infrequently observed despite a relatively prolonged survival. Patients within a kindred have similar survival periods (Table 1), e.g. three died in the study by Weening et al (30) at ages 22, 19, and 32 years (moderate disease); three died in their first year in the studies by Hayward et al and Bissenden et al; and three in Niethammer's study died at 0, 1, and 3 years old (presumably severe disease). In some moderately affected patients, skin lesions may disappear after the first few years of birth, recurring only with occasional infections. Severe gingivitis is always observed in these patients and may be the presenting symptom. Even patients with moderate phenotypes who appear relatively disease-free may, however, rapidly develop infections with complications and die despite strenuous intervention. This is illustrated by the deaths at age 19 and 32 years of siblings of a moderately deficient patient (29, 30).

Delayed umbilical cord separation occurs more frequently in patients with the severe rather than the moderate phenotype, but is not universally found even in the severe phenotype [Table 3 (28)]; since the length of time to separation is greatly affected by hygienic procedures, it is not a reliable indicator of the disease.

### *Functional Abnormalities*

More profound abnormalities of tissue leukocyte infiltration and in vitro chemotaxis, hyperadherence, phagocytosis of iC3b-opsonized particles, and complement or antibody-dependent cytotoxicity were observed among severely as compared to moderately deficient individuals in the Texas series (4). Some of the heterogeneous results between individual patients or kindreds may also reflect methodologic differences among reporting laboratories (2, 4, 12, 15, 19, 22, 24, 27, 29–32, 34, 35, 37, 38, 40). However, as first observed by Crowley et al (12) and later among our patient population (2, 4), abnormalities of granulocyte (and monocyte) adherence to substrates and adhesion-dependent functions including chemotaxis and aggregation have been observed among almost all patients studied. Chemotaxis appears to be affected because it requires adhesion. CR3-dependent binding and phagocytosis of iC3b-opsonized particles is deficient, in agreement with the identity of the CR3 with Mac-1 (55). Opsonized particles are phagocytosed poorly, and hence fail to trigger the respiratory burst (2, 5, 15, 22, 26, 29, 34, 39). Abnormalities of granulocyte

or mononuclear leukocyte antibody-dependent cellular cytotoxicity have also been observed in several patients (4, 7, 65). In contrast, adherence-independent cellular functions including f-Met-Leu-Phe receptor-ligand binding, cell bipolarization, and oxidative metabolism or degranulation when mediated by soluble stimuli are generally normal (2, 4, 19, 22, 27, 31). Intracellular microbicidal activity (*Staphylococcus aureus*) in most, but not all, reported patients is relatively normal (2, 4, 19, 29, 65); this may reflect the presence of quantitatively and qualitatively normal IgG, Fc, CR-1, and other receptors on deficient granulocytes (2-4, 66).

The predominant occurrence of recurrent bacterial (as opposed to viral or fungal) infections in Mac-1-deficient patients implies that the functions of the granulocyte or monocyte are more profoundly affected than are lymphocyte functions. This might be because granulocytes and monocytes normally express Mac-1, LFA-1, and p150,95 while lymphocytes normally express only LFA-1 (1, 67). Not unexpectedly, deficits of LFA-1-dependent lymphocyte functions have been observed in many patients. In other cases, LFA-1-dependent functions are nearly normal but are inhibited by much lower concentrations of monoclonal antibodies to LFA-1 than for normal cells. T-lymphocyte-mediated killing, proliferative responses, natural killing, and antibody-dependent killing by patient lymphocytes are deficient compared to adult controls (7, 8, 22, 23, 27, 34, 38, 65). After primary mixed lymphocyte culture, lymphocytes in several studies demonstrated profoundly diminished cytotoxic and proliferative responses and interferon production (8, 20, 23, 38). However, after secondary and further stimulation, responses increased to nearly normal levels (8). This may be due to compensatory mechanisms, perhaps involving an increase in the affinity of the T-cell antigen receptor, and may account for relatively normal B- and T-lymphocyte function observed in most cases. Delayed cutaneous hypersensitivity reactions are normal among most patients tested, and most individuals demonstrate normal specific antibody synthesis (4, 19, 31). However, impaired T-lymphocyte-dependent antibody responses in vivo (for example, to repeated vaccination with tetanus, diphtheria toxoids, and polio virus), and no in vivo or in vitro antibody production in response to influenzae virus were clearly documented in one patient (25). The deficits of in vivo lymphocyte responses may be found in only some of the severely deficient patients whose  $\beta$  subunit mutation is particularly deleterious to the LFA-1 molecule.

*Deficiency of Upregulation of Mac-1 and p150,95 :  
Relation to Clinical and Histopathologic Features*

Impaired granulocyte hyperadherence and mobility in this clinical disorder appears to be related to impaired mobilization by inflammatory mediators

of intracellular stores of Mac-1 and p150,95 to the cell surface. Whereas a 5- to 10-fold increase in Mac-1 and p150,95 surface expression is consistently demonstrated when normal granulocytes are stimulated with chemotactic factors or PMA *in vitro*, little or no increase in these proteins is observed on patient granulocytes (3, 4, 17, 68). Other functions of patient cells are normally elicited by f-Met-Leu-Phe or PMA, including cell bipolarization, complement receptor-1 "upregulation," release of specific granule contents, and production of superoxide (4). These findings suggest that normal granulocyte hyperadherence and aggregation is mediated by the increased surface expression of Mac-1 and p150,95. Thus, we propose that *in vivo*, chemoattractants diffusing from sites of inflammation into the circulation elicit enhanced cell surface Mac-1 and p150,95, which leads in turn to granulocyte and monocyte aggregation and adherence to endothelial cells at the inflammatory site. Adherence mediated by these glycoproteins may also be essential for granulocyte migration into extravascular sites. The profound inability of patient granulocytes to migrate into inflammatory sites appears related to a lack of enhancement of cell adhesion to vascular endothelium. Several studies found patient granulocytes and monocytes to be deficient in adherence to endothelial cells (21, 69, but see 14) or to fibronectin-coated substrates (14).

### *Inhibition of Adherence-Dependent Functions by Anti-Mac-1 MAbs*

In recent studies, the defects in patient cells have been reproduced in normal cells by treating them with MAb (10, 20, 70). Inhibitory effects of MAbs specific for individual  $\alpha$  subunits indicate distinct adhesive contributions of each  $\alpha\beta$  complex (10). Anti- $\alpha$ M,  $\alpha$ X, and  $-\beta$  MAbs inhibit adherence of granulocytes both under baseline conditions and when increased surface expression of  $\alpha$ M $\beta$  and  $\alpha$ X $\beta$  complexes is stimulated by inflammatory mediators. A higher percentage of cells adhere after stimulation; both stimulated and baseline adherence are almost completely inhibited by anti- $\beta$ -subunit and anti-Mac-1 $\alpha$ -subunit MAb. The general order of potency of inhibition is anti- $\beta$  > anti-Mac-1 $\alpha$   $\gg$  anti-p150,95 $\alpha$  > anti-LFA-1 $\alpha$ , which reflects the relative amounts of each molecule expressed on granulocyte surfaces. Inhibition of directed migration by anti- $\beta$ , or anti- $\alpha$ M MAbs is observed in subagarose (two-dimensional) but not Boyden chemotaxis assays. Inhibition is dependent upon a continuous cell exposure to anti-Mac-1 $\alpha$  or  $\beta$  during the assay, which suggests that recycled or new Mac-1 is required for directed translocation. Phagocytosis of particles selectively opsonized with C3-derived ligands and binding of iC3b-opsonized sheep red blood cells are generally inhibitable by anti- $\alpha$ M MAbs but not by anti- $\beta$ ,  $-\alpha$ L, or  $-\alpha$ X MAbs. These findings suggest

the Mac-1 molecule demonstrates "nonspecific" adhesive properties in addition to a specific capacity to recognize and bind iC3b. Notably, none of the anti-Mac-1 MAbs demonstrate inhibitory effects in assays of adherence-independent functions that are normal among genetically deficient cell suspensions. These studies prove that the functional deficiencies in patient cells are due to lack of the Mac-1, LFA-1, and p150,95 glycoproteins.

### *Therapy*

**BONE MARROW TRANSPLANTATION** Bone marrow transplantation with successful engraftment of donor cells completely restored leukocyte function and rendered unnecessary any further treatment in two patients (4, 44). In two other patients, successful engraftment was achieved, but recovery did not occur either because of graft-versus-host disease or infectious complications. Transplantation is recommended for severely deficient patients because of the high incidence of death before the age of 2 (22; Table 1). Moderately deficient patients live longer but may also die from infections; the occurrence of deaths at the ages of 19, 22, and 32 (Table 1) and the absence of any known patients older than 38 years shows that survival through adolescence is no guarantee of a long life. Therapeutic guidelines for management of moderately deficient patients are not well defined.

**USE IN TRANSPLANTATION IN OTHER TYPES OF DISEASES OF LFA-1 MAb IN VIVO** HLA-mismatched bone marrow transplantation has proven successful in many different diseases recently, in part because of depletion of donor T cells to prevent graft-versus-host disease. However, the incidence of donor rejection of the graft has become more troublesome. Fischer et al (44) observed that LFA-1-deficient patients, none of whom mounted allogeneic mixed lymphocyte responses, did not reject grafts. Since (a) graft rejection can be mediated by both T and non-T cells, (b) LFA-1 MAbs inhibit both T and natural killer immune functions in vitro (58), and (c) LFA-1 is not on hematopoietic stem cells (49, 50), Fischer et al treated graft recipients with 0.1 mg/kg anti-LFA-1  $\alpha$ -subunit MAb from three days before to five days after transplantation. Recipients had a variety of inherited diseases such as Wiskott-Aldrich syndrome and osteopetrosis, and all received HLA-mismatched transplants. The use of LFA-1 MAb resulted in seven of seven successful engraftments, a dramatic improvement over the previous experience. Thus, the clinical experience with LAD and concepts based on the functional effects of LFA-1 MAb in vitro have led to new treatment modalities in the therapy of other diseases.

**GENE THERAPY** The identification of the genetic lesion in LAD in the common  $\beta$  subunit of the Mac-1, LFA-1 glycoprotein family predicts that



introduction of a normal  $\beta$ -subunit gene into hematopoietic cells should cure the disease. The mouse  $\beta$  subunit has been shown to complex with and rescue surface expression of the patient LFA-1  $\alpha$  subunit in patient  $\times$  mouse lymphocyte hybrids (11). Recently, a cDNA clone for the  $\beta$  subunit was obtained (T. K. Kishimoto, T. Roberts, and T. A. Springer, unpublished). Efforts are now being directed towards introducing (via retroviral vectors) the  $\beta$ -subunit gene into bone marrow cells, with the goal of curing this disease through gene therapy.

#### Literature Cited

- Sanchez-Madrid, F., Nagy, J., Robbins, E., Simon, P., Springer, T. A. 1983. A human leukocyte differentiation antigen family with distinct alpha subunits and a common beta subunit: the lymphocyte function-associated antigen (LFA-1), the C3bi complement receptor (OKM-1/Mac-1), and the p150,95 molecule. *J. Exp. Med.* 158: 1785-1803
- Anderson, D. C., Schmalstieg, F. C., Arnaout, M. A., Kohl, S., Tosi, M. F., et al. 1984. Abnormalities of polymorphonuclear leukocyte function associated with a heritable deficiency of high molecular weight surface glycoproteins (GPI38): Common relationship to diminished cell adherence. *J. Clin. Invest.* 74: 536-51
- Springer, T. A., Thompson, W. S., Miller, L. J., Schmalstieg, F. C., Anderson, D. C. 1984. Inherited deficiency of the Mac-1, LFA-1, p150,95 glycoprotein family and its molecular basis. *J. Exp. Med.* 160: 1901-18
- Anderson, D. C., Schmalstieg, F. C., Finegold, M. J., Hughes, B. J., Rothlein, R., et al. 1985. The severe and moderate phenotypes of heritable Mac-1, LFA-1 deficiency: Their quantitative definition and relation to leukocyte dysfunction and clinical features. *J. Infect. Dis.* 152: 668-89
- Abramson, J. S., Mills, E. L., Sawyer, M. K., Regelmann, W. R., Nelson, J. D., Quie, P. G. 1981. Recurrent infections and delayed separation of the umbilical cord in an infant with abnormal phagocytic cell locomotion and oxidative response during particle phagocytosis. *J. Pediatr.* 99: 887-94
- Issekutz, A. C., Lee, K. Y., Biggar, W. D. 1979. Combined abnormality of neutrophil chemotaxis and bactericidal activity in a child with chronic skin infections. *Clin. Immunol. Immunopathol.* 14: 1-10
- Kohl, S., Springer, T. A., Schmalstieg, F. C., Loo, L. S., Anderson, D. C. 1984. Defective natural killer cytotoxicity and polymorphonuclear leukocyte antibody-dependent cellular cytotoxicity in patients with LFA-1/OKM-1 deficiency. *J. Immunol.* 133: 2972-78
- Krensky, A. M., Mentzer, S. J., Clayberger, C., Anderson, D. C., Schmalstieg, F. C., et al. 1985. Heritable lymphocyte function-associated antigen-1 deficiency: Abnormalities of cytotoxicity and proliferation associated with abnormal expression of LFA-1. *J. Immunol.* 135: 3102-8
- Springer, T. A., Miller, L. J., Anderson, D. C. 1986. p150,95, the third member of the Mac-1, LFA-1 human leukocyte adhesion glycoprotein family. *J. Immunol.* 136: 240-45
- Anderson, D. C., Miller, L. J., Schmalstieg, F. C., Rothlein, R., Springer, T. A. 1986. Contributions of the Mac-1 glycoprotein family to adherence-dependent granulocyte functions: Structure-function assessments employing subunit-specific monoclonal antibodies. *J. Immunol.* 137: 15-27
- Marlin, S. D., Morton, C. C., Anderson, D. C., Springer, T. A. 1986. LFA-1 immunodeficiency disease: Definition of the genetic defect and chromosomal mapping of alpha and beta subunits by complementation in hybrid cells. *J. Exp. Med.* In press
- Crowley, C. A., Curnutte, J. T., Rosin, R. E., Andre-Schwartz, J., Gallin, J. L., et al. 1980. An inherited abnormality of neutrophil adhesion: Its genetic transmission and its association with a missing protein. *N. Engl. J. Med.* 302: 1163-68
- Arnaout, M. A., Spits, H., Terhorst, C., Pitt, J., Todd, R. F. III. 1984. Deficiency of a leukocyte surface glycoprotein (LFA-1) in two patients with Mol deficiency. *J. Clin. Invest.* 74: 1291-1300
- Buchanan, M. R., Crowley, C. A., Rosin, R. E., Gimbrone, M. A., Babior, B. M. 1982. Studies on the interaction

- between GP-180-deficient neutrophils and vascular endothelium. *Blood* 60: 160-65
15. Arnaout, M. A., Pitt, J., Cohen, H. J., Melamed, J., Rosen, F. S., Colten, H. R. 1982. Deficiency of a granulocyte-membrane glycoprotein (gp150) in a boy with recurrent bacterial infections. *N. Engl. J. Med.* 306: 693-99
  16. Dana, N., Todd, R. F. III, Pitt, J., Springer, T. A., Arnaout, M. A. 1984. Deficiency of a surface membrane glycoprotein (Mol) in man. *J. Clin. Invest.* 73: 153-59
  17. Todd, R. F. I., Arnaout, M. A., Rosin, R. E., Crowley, C. A., Peters, W. A., Babior, B. M. 1984. Subcellular localization of the large subunit of Mol (Mol alpha; formerly gp110), a surface glycoprotein associated with neutrophil adhesion. *J. Clin. Invest.* 74: 1280-90
  18. Arnaout, M. A., Todd, R. F. III, Dana, N., Melamed, J., Schlossman, S. F., Colten, H. R. 1983. Inhibition of phagocytosis of complement C3- or immunoglobulin G-coated particles and of C3bi binding by monoclonal antibodies to a monocyte-granulocyte membrane glycoprotein (Mol). *J. Clin. Invest.* 72: 171-79
  19. Bowen, T. J., Ochs, H. D., Altman, L. C., Price, T. H., Van Epps, D. E., et al. 1982. Severe recurrent bacterial infections associated with defective adherence and chemotaxis in two patients with neutrophils deficient in a cell-associated glycoprotein. *J. Pediatr.* 101: 932-40
  20. Beatty, P. G., Harlan, J. M., Rosen, H., Hansen, J. A., Ochs, H. D., et al. 1984. Absence of monoclonal-antibody-defined protein complex in a boy with abnormal leucocyte function. *Lancet* 1: 535-37
  21. Harlan, J. M., Killen, P. D., Senecal, F. M., Schwartz, B. R., Yee, E. K., et al. 1985. The role of neutrophil membrane glycoprotein GP-150 in neutrophil adherence to endothelium in vitro. *Blood* 66: 167-78
  22. Fischer, A., Descamps-Latscha, B., Gerota, I., Scheinmetzler, C., Virelizier, J. L., et al. 1983. Bone-marrow transplantation for inborn error of phagocytic cells associated with defective adherence, chemotaxis, and oxidative response during opsonised particle phagocytosis. *Lancet* 2: 473-76
  23. Fischer, A., Seger, R., Durandy, A., Grosppierre, B., Virclizier, J. L., et al. 1985. Deficiency of the adhesive protein complex lymphocyte function antigen 1, complement receptor type 3, glycoprotein p150,95 in a girl with recurrent bacterial infections. *J. Clin. Invest.* 76: 2385-92
  24. Lisowska-Grosppierre, B., Bohler, M. C., Fischer, A., Mawas, C., Springer, T. A., Griscelli, G. 1986. Defective membrane expression of the LFA-1 complex may be secondary to the absence of the beta chain in a child with recurrent bacterial infection. *Mol. Immunol.* In press
  25. Fischer, A., Durandy, A., Sterkers, G., Griscelli, C. 1986. Role of the LFA-1 molecule in cellular interactions required for antibody production in humans. *J. Immunol.* 136: 3198-3203
  26. Thompson, R. A., Candy, D. C. A., McNeish, A. S. 1984. Familial defect of polymorph neutrophil phagocytosis associated with absence of a surface glycoprotein antigen (OKMI). *Clin. Exp. Immunol.* 58: 229-36
  27. Ross, G. D., Thompson, R. A., Walport, M. J., Springer, T. A., Watson, J. V., et al. 1985. Characterization of patients with an increased susceptibility to bacterial infections and a genetic deficiency of leukocyte membrane complement receptor type 3 and the related membrane antigen LFA-1. *Blood* 66: 882-90
  28. Ross, G. D. 1986. Characterization of phagocytic and cytotoxic abnormalities in patients who have an inherited deficiency of neutrophil complement receptor type three (CR3) and the related membrane antigens LFA-1 and p150,95. In: *Recent Advances in Primary and Acquired Immunodeficiencies*, Sero Symposium, Vol. 28, ed. F. Aiuti, F. Rosen, M. D. Cooper. New York: Raven
  29. Weening, R. S., Roos, D., Weemaes, C. M. R., Homan-Muller, J. W. T., van Schaik, M. L. J. 1976. Defective initiation of the metabolic stimulation in phagocytizing granulocytes: a new congenital defect. *J. Lab. Clin. Med.* 88: 757-68
  30. Miedema, F., Tetteroo, P. A. T., Terpstra, F. G., Keizer, G., Roos, M., et al. 1985. Immunologic studies with LFA-1 and Mol-deficient lymphocytes from a patient with recurrent bacterial infections. *J. Immunol.* 134: 3075-81
  31. Buescher, E. S., Gaither, T., Nath, J., Gallin, J. I. 1985. Abnormal adherence-related functions of neutrophils, monocytes, and Epstein-Barr virus-transformed B cells in a patient with C3bi receptor deficiency. *Blood* 65: 1382-90
  32. Fujita, K., Kobayashi, K., Uchida, M., Kajii, T. 1986. Neutrophil adhesion abnormality with deficient surface membrane proteins (gp 110 and p 98): The effect of their antibodies on the function

- of normal neutrophils. *Pediatr. Res.* 20: 361-66
33. Kobayashi, K., Fujita, K., Okino, F., Kajii, T. 1984. An abnormality of neutrophil adhesion: Autosomal recessive inheritance associated with missing neutrophil glycoproteins. *Pediatrics* 73: 606-10
  34. Weisman, S. J., Berkow, R. L., Plautz, G., Torres, M., McGuire, W. A., et al. 1985. Glycoprotein-180 deficiency: Genetics and abnormal neutrophil activation. *Blood* 65: 696-704
  35. Boxer, L. A., Hedley-Whyte, E. T., Stossel, T. P. 1974. Neutrophil actin dysfunction and abnormal neutrophil behavior. *N. Engl. J. Med.* 291: 1093-99
  36. Southwick, F. S., Holbrook, T., Howard, T., Springer, T., Stossel, T. P., Arnaout, M. A. 1986. Neutrophil actin dysfunction is associated with a deficiency of Mol. *Clin. Res.* 34: 533A
  37. Hayward, A. R., Leonard, J., Wood, C. B. S., Harvey, B. A. M., Greenwood, M. C., Soothill, J. F. 1979. Delayed separation of the umbilical cord, widespread infections, and defective neutrophil mobility. *Lancet* 1: 1099-1101
  38. Davies, E. G., Isaacs, D., Levinsky, R. J. 1982. Defective immune interferon production and natural killer activity associated with poor neutrophil mobility and delayed umbilical cord separation. *Clin. Exp. Immunol.* 50: 454-60
  39. Harvath, L., Andersen, B. R. 1979. Defective initiation of oxidative metabolism in polymorphonuclear leukocytes. *N. Engl. J. Med.* 300: 1130-35
  40. Bissenden, J. G., Haeney, M. R., Tarlow, M. J., Thompson, R. A. 1981. Delayed separation of the umbilical cord, severe widespread infections, and immunodeficiency. *Arch. Dis. Childhood* 56: 397-99
  41. Niethammer, D., Dieterle, U., Kleihauer, E., Wildfeuer, A., Haferkamp, O., Hitzig, W. H. 1975. An inherited defect in granulocyte function: Impaired chemotaxis, phagocytosis and intracellular killing of microorganisms. *Helv. Paediat. Acta* 30: 537-41
  42. Springer, T. A., Unkeless, J. C. 1984. Analysis of macrophage differentiation and function with monoclonal antibodies. In *Contemporary Topics in Immunobiology*, Vol. 14, ed. D. O. Adams, M. G. Hanna Jr. New York: Plenum
  43. Springer, T. A. 1985. The LFA-1, Mac-1 glycoprotein family and its deficiency in an inherited disease. *Fed. Proc.* 44: 2660-63
  44. Fischer, A., Blanche, S., Veber, F., LeDeist, F., Gerota I., et al. 1986. Correlation of immune disorders by HLA matched and mismatched bone marrow transplantation. In *Recent Advances in Bone Marrow Transplantation*, ed. R. P. Gale. New York: Liss. In press
  45. Anderson, D. C., Schmalstieg, F. C., Shearer, W., Becker-Freeman, K., Kohl, S., et al. 1985. Leukocyte LFA-1, OKM1, p150,95 deficiency syndrome: functional and biosynthetic studies in three kindreds. *Fed. Proc.* 44: 2671-77
  46. Springer, T. A., Davignon, D., Ho, M. K., Kürzinger, K., Martz, E., Sanchez-Madrid, F. 1982. LFA-1 and Lys-2,3, molecules associated with T lymphocyte-mediated killing; and Mac-1, an LFA-1 homologue associated with complement receptor function. *Immunol. Rev.* 68: 111-35
  47. Springer, T. A., Anderson, D. C. 1986. The importance of the Mac-1, LFA-1 glycoprotein family in monocyte and granulocyte adherence, chemotaxis, and migration into inflammatory sites: Insights from an experiment of nature. In *Biochemistry of Macrophages* (Ciba Symposium 118). London: Pitman
  48. Flotte, T., Springer, T. A., Thorbecke, G. J. 1983. Dendritic cell and macrophage staining by monoclonal antibodies in tissue sections and epidermal sheets. *Am. J. Pathol.* 111: 112-24
  49. Miller, B. A., Antognetti, G., Springer, T. 1985. Identification of cell surface antigens present on murine hematopoietic stem cells. *J. Immunol.* 134: 3286-90
  50. Campana, D., Sheridan, B., Tidman, N., Hoffbrand, A. V., Janossy, G. 1986. Human leukocyte function-associated antigens on lympho-hematopoietic precursor cells. *Eur. J. Immunol.* 16: 537-42
  51. Springer, T. A., Anderson, D. C. 1986. Antibodies specific for the Mac-1, LFA-1, p150,95 glycoproteins or their family, or for other granulocyte proteins. In the 2nd Int. Workshop on Human Leukocyte Differentiation Antigens, *Leukocyte Typing II: Volume 3, Human Myeloid and Hematopoietic Cells*, ed. E. L. Reinherz, B. F. Haynes, L. M. Nadler, I. D. Bernstein. New York: Springer-Verlag
  52. Kürzinger, K., Ho, M. K., Springer, T. A. 1982. Structural homology of a macrophage differentiation antigen and an antigen involved in T-cell-mediated killing. *Nature* 296: 668-70
  53. Sanchez-Madrid, F., Simon, P., Thompson, S., Springer, T. A. 1983. Mapping of antigenic and functional epitopes on the alpha and beta subunits of two re-

- lated glycoproteins involved in cell interactions, LFA-1 and Mac-1. *J. Exp. Med.* 158: 586-602
54. Springer, T. A., Teplow, D. B., Dreyer, W. J. 1985. Sequence homology of the LFA-1 and Mac-1 leukocyte adhesion glycoproteins and unexpected relation to leukocyte interferon. *Nature* 314: 540-42
  55. Beller, D. I., Springer, T. A., Schreiber, R. D. 1982. Anti-Mac-1 selectively inhibits the mouse and human type three complement receptor. *J. Exp. Med.* 156: 1000-9
  56. Wright, S. D., Rao, P. E., Van Voorhis, W. C., Craigmyle, L. S., Iida, K., et al. 1983. Identification of the C3bi receptor of human monocytes and macrophages with monoclonal antibodies. *Proc. Natl. Acad. Sci. USA* 80: 5699-5703
  57. Micklem, K. J., Sim, R. B. 1985. Isolation of complement-fragment-iC3b-binding proteins by affinity chromatography. *Biochem. J.* 231: 233-36
  58. Springer, T. A., Dustin, M. L., Kishimoto, T. K., Marlin, S. D. 1987. Lymphocyte function associated (LFA) molecules: Cell adhesion receptors of lymphocytes. *Ann. Rev. Immunol.* In press
  59. Gallin, J. I., Rosenthal, A. S. 1974. The regulatory role of divalent cations in human granulocyte chemotaxis. *J. Cell Biol.* 62: 594-609
  60. Lanier, L. L., Arnaout, M. A., Schwartzing, R., Warner, N. L., Ross, G. D. 1985. p150/95, third member of the LFA-1/CR3 polypeptide family identified by anti-Leu M5 monoclonal antibody. *Eur. J. Immunol.* 15: 713-18
  61. Ho, M. K., Springer, T. A. 1983. Biosynthesis and assembly of the alpha and beta subunits of Mac-1, a macrophage glycoprotein associated with complement receptor function. *J. Biol. Chem.* 258: 2766-69
  62. Sastre, L., Kishimoto, T. K., Gee, C., Roberts, T., Springer, T. A. 1986. The mouse leukocyte adhesion proteins Mac-1 and LFA-1: Studies on mRNA translation and protein glycosylation. *J. Immunol.* 137: 1060-65
  63. Sastre, L., Roman, J., Teplow, D., Dreyer, W., Gee, C., et al. 1986. A partial genomic DNA clone for the alpha subunit of the mouse complement receptor type 3 and cellular adhesion molecule Mac-1. *Proc. Natl. Acad. Sci. USA.* In press
  64. Waldrop, T. C., Anderson, D. C., Hallmon, W. W., Schmalstieg, F. C., Jacobs, R. L. 1986. Periodontal manifestations of the heritable Mac-1, LFA-1 deficiency syndrome—clinical, histopathologic and molecular characteristics. *J. Periodont.* In press
  65. Kohl, S., Loo, L. S., Schmalstieg, F. S., Anderson, D. C. 1986. The genetic deficiency of leukocyte surface glycoproteins Mac-1, LFA-1, p150,95 in humans is associated with defective antibody-dependent cellular cytotoxicity in vitro and defective protection against herpes simplex virus infection in vivo. *J. Immunol.* In press
  66. O'Shea, J. J., Brown, E. J., Seligmann, B. E., Metcalf, J. A., Frank, M. M., Gallin, J. I. 1985. Evidence for distinct intracellular pools of receptors for C3b and C3bi in human neutrophils. *J. Immunol.* 134: 2580-87
  67. Krensky, A. M., Sanchez-Madrid, F., Robbins, E., Nagy, J., Springer, T. A., Burakoff, S. J. 1983. The functional significance, distribution, and structure of LFA-1, LFA-2, and LFA-3: cell surface antigens associated with CTL-target interactions. *J. Immunol.* 131: 611-16
  68. Berger, M., O'Shea, J., Cross, A. S., Folks, T. M., Chused, T. M., et al. 1984. Human neutrophils increase expression of C3b receptors upon activation. *J. Clin. Invest.* 74: 1566-71
  69. Tonnesen, M. G., Anderson, D. C., Springer, T. A., Knedler, A., Avdi, N., Henson, P. M. 1986. Mac-1 glycoprotein family mediates adherence of neutrophils to endothelial cells stimulated by leukotriene B<sub>4</sub> and platelet-activating factor. *Fed. Proc.* 45: 379
  70. Schwartz, B. R., Ochs, H. D., Beatty, P. G., Harlan, J. M. 1985. A monoclonal antibody-defined membrane antigen complex is required for neutrophil-neutrophil aggregation. *Blood* 65: 1553-56